

JSRULP Series

Ultra Low Pressure Reducing Valves for Bio-Pharm Gas Applications

JSRULP is a high purity gas low pressure regulator designed and built specifically for hygienic, ASME BPE gas applications.

The JSRULP has been designed specifically for very low pressure clean gas regulation in stainless and single use disposable applications. Whether it's precise regulation for blanketing, motive force, fluid movement or SUD bag inflation, the JSRULP was built for the job!

The durable valve body and stainless trim components are machined from ASME SA479 316L SST barstock and finished to ASME BPE SF5, [20Ra μ m (0.5 Ra μ m) electro-polished] standard. The valve is outfitted with a thin Jorlon diaphragm and EPDM seats and seals that are all FDA approved, and USP Class VI compliant. The EPDM seat reduces lockup to less than 0.5" wc (1.24 mbar) on this model.

FEATURES

- No exposed threaded connections below diaphragm
- In-line removable seat and trim facilitate cleaning and routine maintenance
- Barstock construction guarantees material integrity and surface finish
- Very low lockup with EPDM seat material
- High rangeability and relatively low set point offset lessens the need for reduced trim sizes
- Minimized internal volume
- Proprietary Jorlon diaphragm material provides exceptionally long life
- Soft seat material for ANSI Class VI shutoff

DOCUMENTATION

The following documentation is shipped at no charge:

- Steriflow Unicert, a QC signed Certificate of Compliance for:
 - Material, listing heat numbers with attached MTR's
 - Surface Finish
 - FDA/USP Class VI - for all thermoplastic and elastomers
- Traceability:
 - Each individual product serial number is traceable to the Unicert serial number, heat numbers and attached MTR's

Other documents must be requested at time of RFQ, or order:

- ADI/TSE Free, Certified Test reports, Certificate of Origin.

EPDM seat for low lockup and tight shutoff



APPLICATIONS

The JSRULP is a pressure regulating valve ideal for low flow, very low pressure precision regulation of clean compressed air and gas used in pharmaceutical and biopharmaceutical R&D, Pilot, and Production facilities.

It is designed specifically for use on traditional Stainless Steel and Single Use Disposable applications including:

- Small sterile vessels:
 - Gas overlay (blanketing)
 - SUD bag integrity testing/inflation
- Incubators
- Time/pres filling machine product hold vessels

Suitable for clean compressed gas, including:

- Air
- Nitrogen
- Carbon Dioxide
- Oxygen
- Argon
- Custom gas mixtures

SPECIFICATIONS

Sizes: 1/2" (DN15) & 3/4" (DN20)

Soft Seat Materials for ANSI Class VI Shut-Off:

- EPDM to +300°F (150°C) FDA, USP Class VI*

Body Material and Trim: ASME SA479 316L (UNS 31603) is standard. EN 10272:2000 GR 1.4435, AL-6XN®, Hastelloy®C-22 and others are optional.

Lower and Upper Diaphragm Case: ASTM A167 316/316L

Diaphragm Material: Thin Jorlon FDA, USP Class VI

Maximum Inlet Pressure: 150 psig (10,5 bar)

Maximum Outlet Pressure: 25 psig (1,7 bar)

Optional Cleaning Specifications

- Clean for Oil-Free
- O2 Cleaning complying with ASTM G93-03 2011 and CGA G-4.1-2009

Spring Ranges: 3-18" wc (0.11-0.65 psi, 7.47-44.79 mbar); Contact factory for other spring ranges.

Flow Characteristics:

- High Flow: Trim Cv 0.8;
Cv for relief valve sizing is 0.9
- Low Flow: Trim Cv 0.5;
Cv for relief valve sizing is 0.6

Surface Finish:

- Wetted Internal surface finish: Mechanically polished, and electropolished to ASME BPE SF5, 20 Ra µin (0.5 Ra µm) as standard*
- Exterior surface finish: Mechanically polished, and electropolished to 40 Ra µin (1.0 Ra µm) as standard
- Other finishes available upon request

Options:

- Panel Mounting

Note: For a complete ancillary list of all wetted and non-wetted material specifications, please contact Steriflow Valve.

* NPT treaded end valves: Threads are not 20 Ra (0.5 Ra). Bottom of outlet cavities (inlet, outlet, or gauge ports) are machine finish only. They cannot be polished to spec without damaging the treads. For pure gas installations, Tri-clamp, or weld end connections recommended if specific surface finish is required at bottom of cavity ports.

FEATURES & BENEFITS

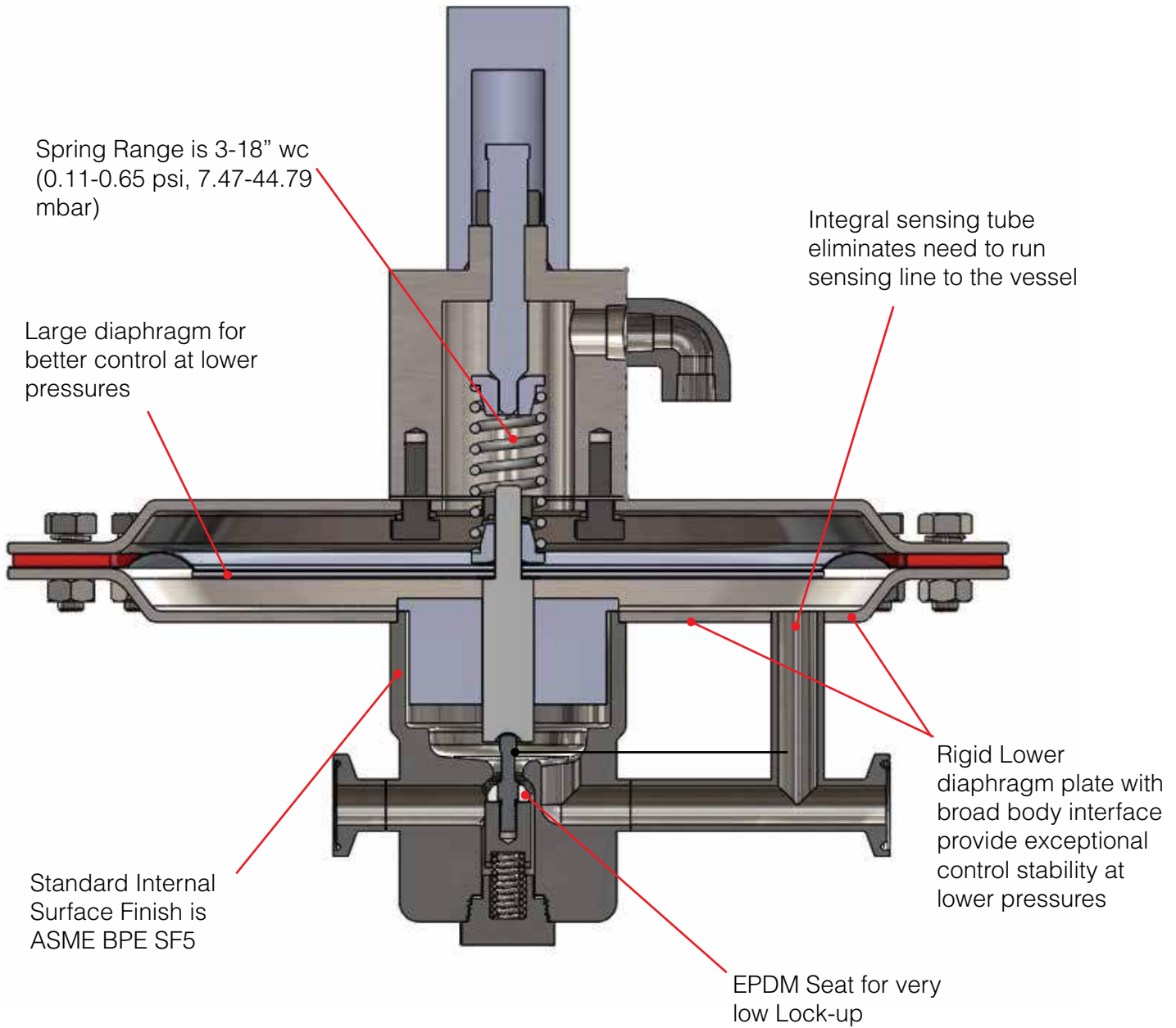

Cv TRIM SELECTION INSTRUCTIONS

To select a valve with the proper Cv:

1. Each graph on the following pages represents test curves for a particular trim (Cv) and inlet pressure. The Cv and inlet pressure are listed at the top of each graph. The valves flow performance at various outlet pressure set points is represented by the sloped horizontal lines.
2. Look through the following pages and select the graph that best represents your inlet pressure, and flow range.
3. Once you have selected a graph, look for the horizontal sloped line that comes closest to your application's actual set point pressure. That line indicates the Pressure/Flow capabilities and offset (droop) of that particular Cv under flowing conditions.

Note:

If there isn't a graph for your specific inlet pressure, choose the two closest inlet pressure graphs with the same Cv. Look at the sloped outlet pressure/flow performance curve for both. Your valve's performance will fall between those two graphs. Contact your factory representative if questions.

To convert gas flow rates to the air flow rates shown in the following graphs, multiply the gas flows by the conversion factor listed below.

For example: to convert an Argon flow range of 0.17 to 1.7 LPM to equivalent air flow rates that you can use with the graphs below, multiply each Argon flow rate by 1.18. The air flow range equivalent would be: (0.17 LPM Argon x 1.18) to (1.7 LPM Argon x 1.18), or 0.2 LPM Air to 2.0 LPM air.

Argon 1.18

Carbon Dioxide 1.23

Nitrogen 0.98

Oxygen 1.05

FLOW DATA FOR Cv TRIM SELECTION

The graphs illustrate the change or "droop" in outlet pressures as the flow rate increases, and the lockup (setpoint rise) as flow decreases and approaches zero. **Your applications outlet pressure set points cannot be lower than those indicated on each graph.**

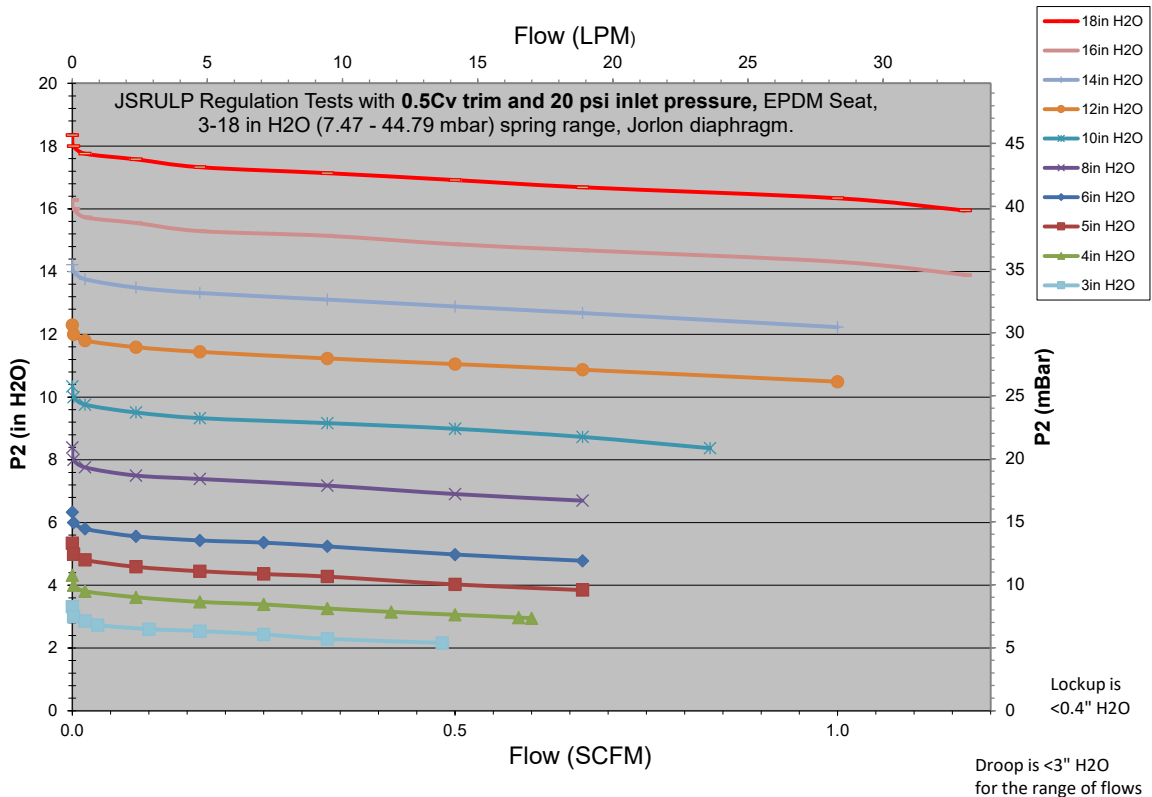
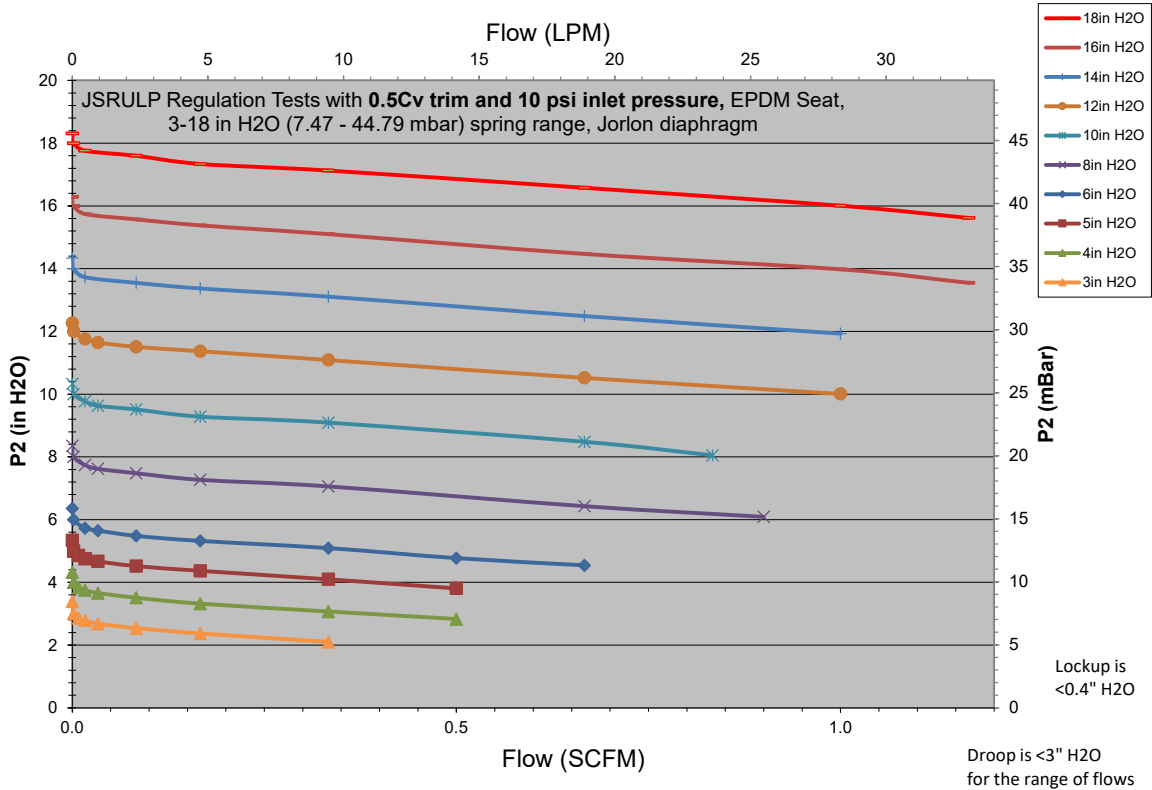

FLOW DATA FOR Cv TRIM SELECTION

The graphs illustrate the change or "droop" in outlet pressures as the flow rate increases, and the lockup (setpoint rise) as flow decreases and approaches zero.

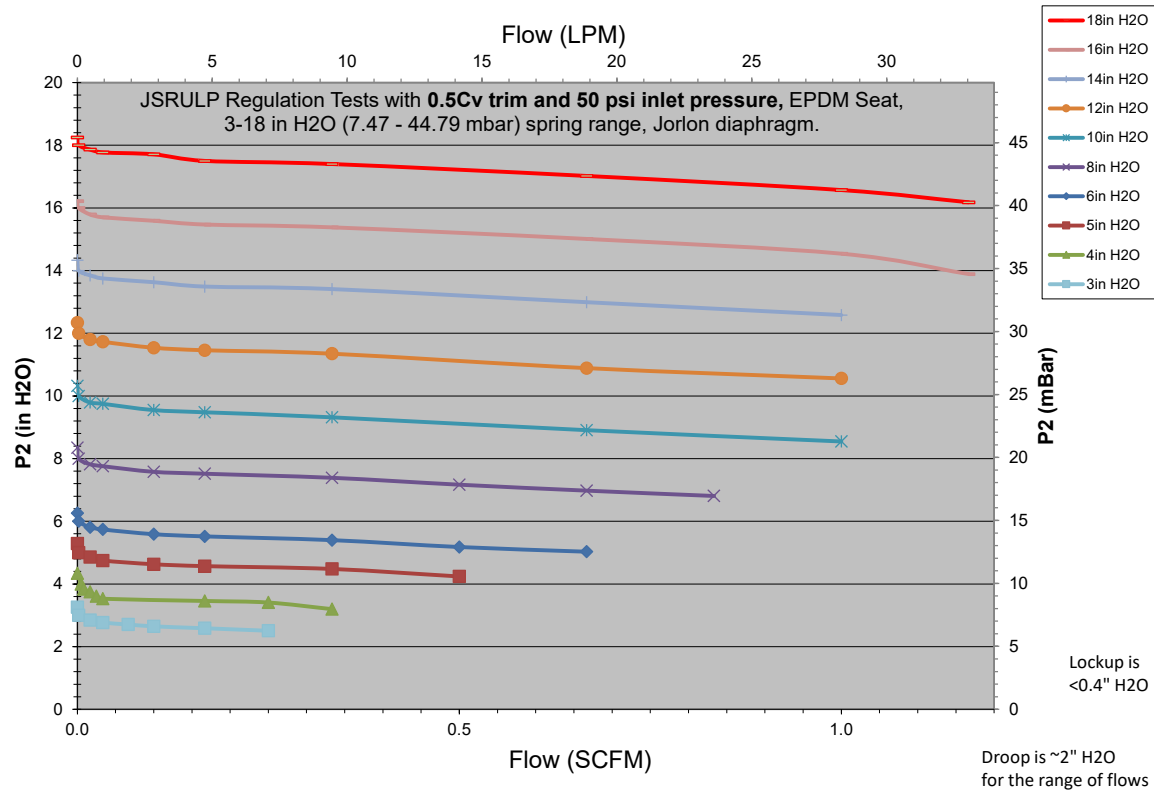
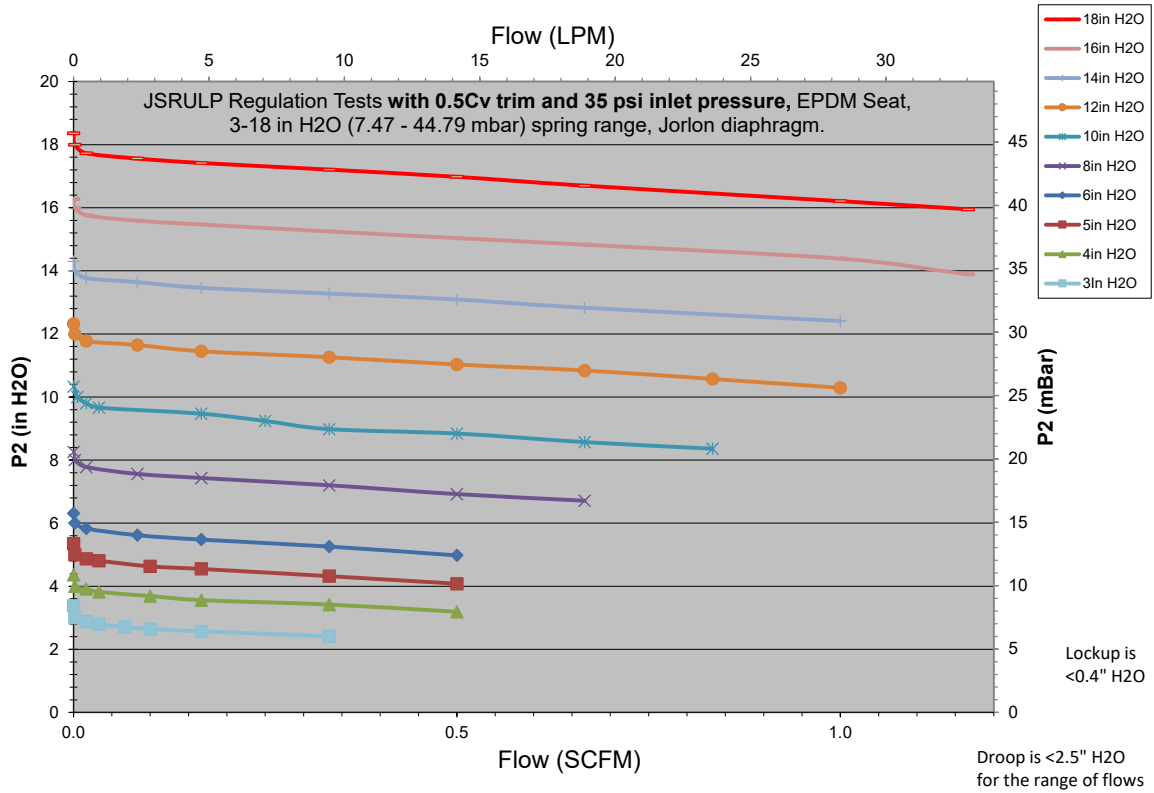

FLOW DATA FOR Cv TRIM SELECTION

The graphs illustrate the change or "droop" in outlet pressures as the flow rate increases, and the lockup (setpoint rise) as flow decreases and approaches zero.

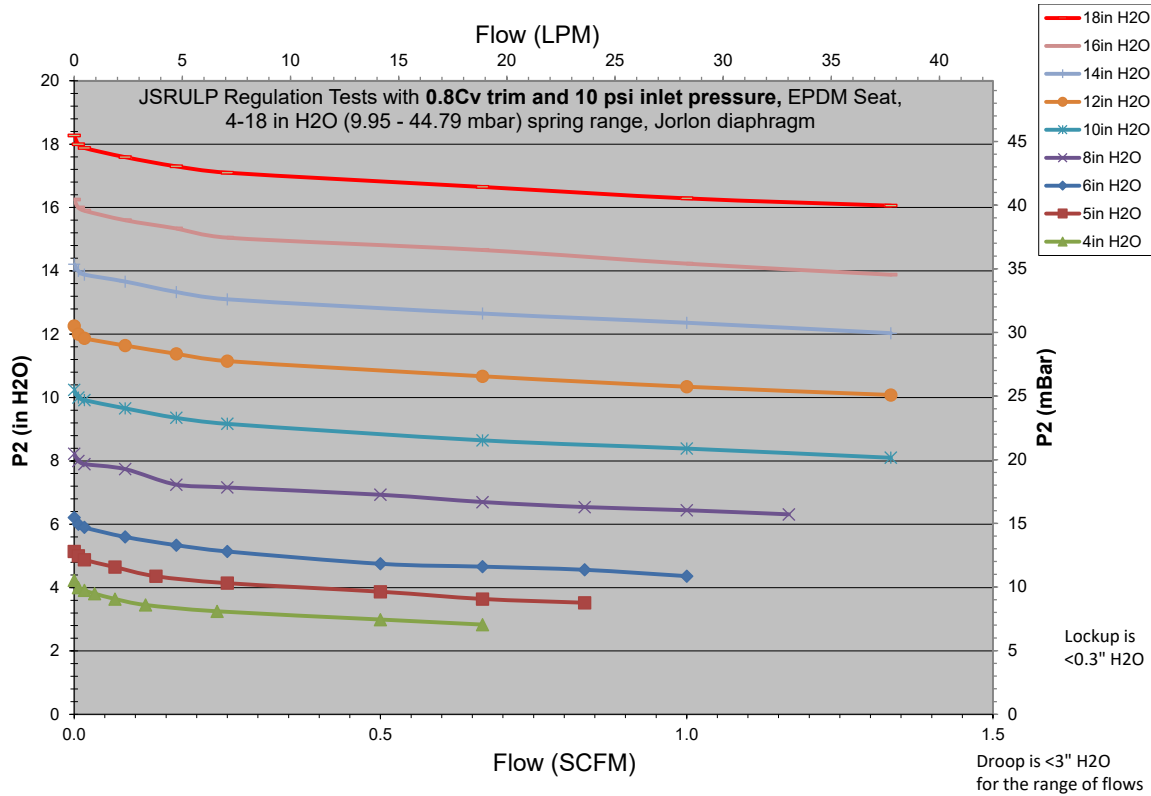
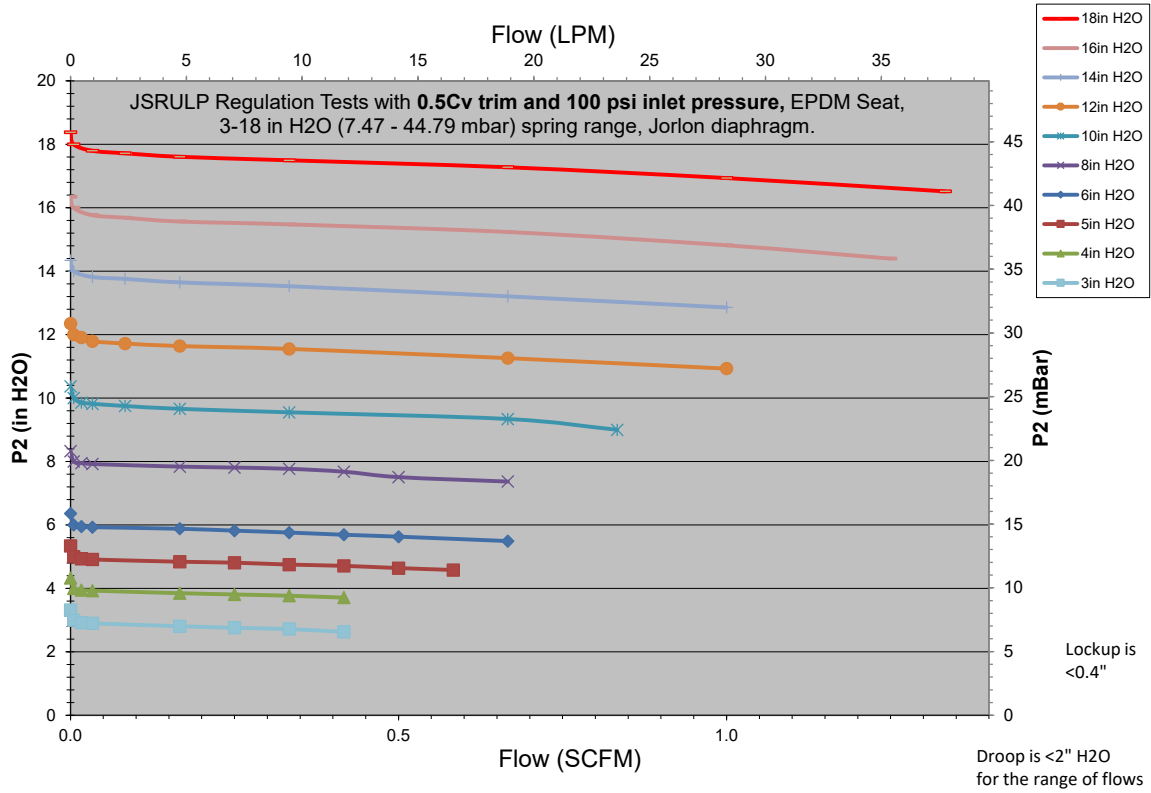

FLOW DATA FOR Cv TRIM SELECTION

The graphs illustrate the change or "droop" in outlet pressures as the flow rate increases, and the lockup (setpoint rise) as flow decreases and approaches zero.

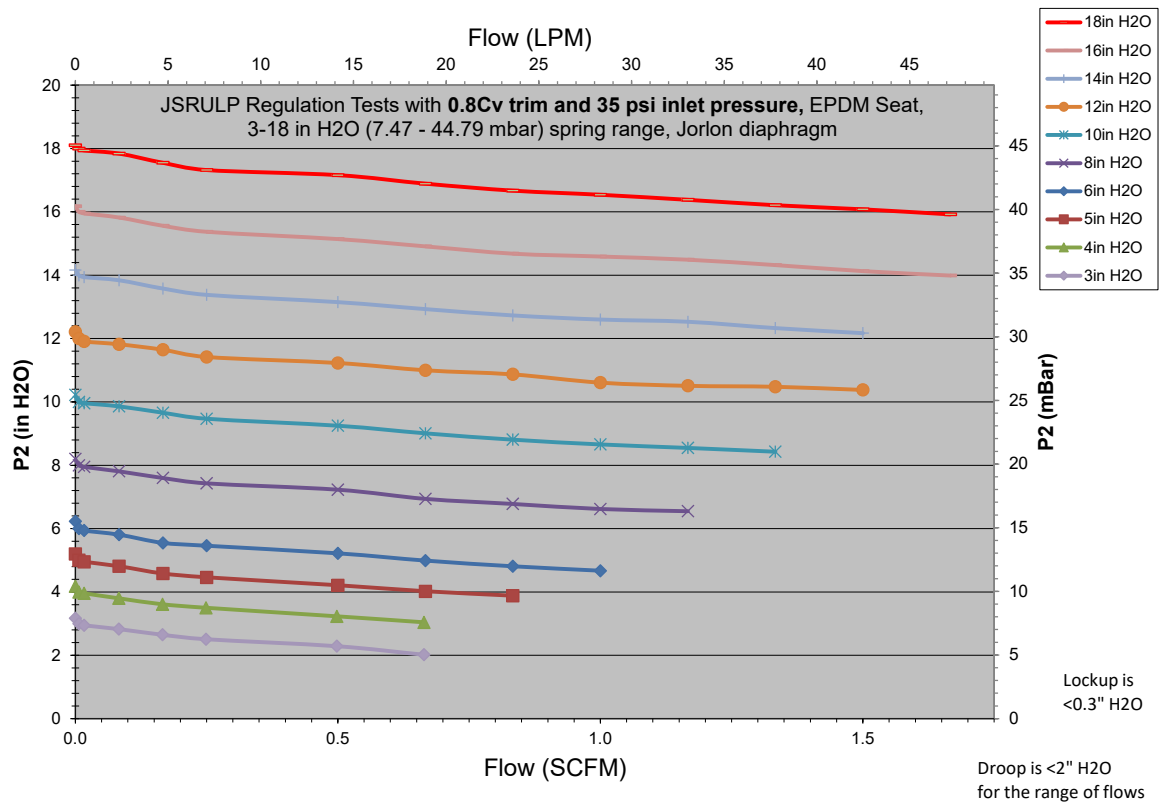
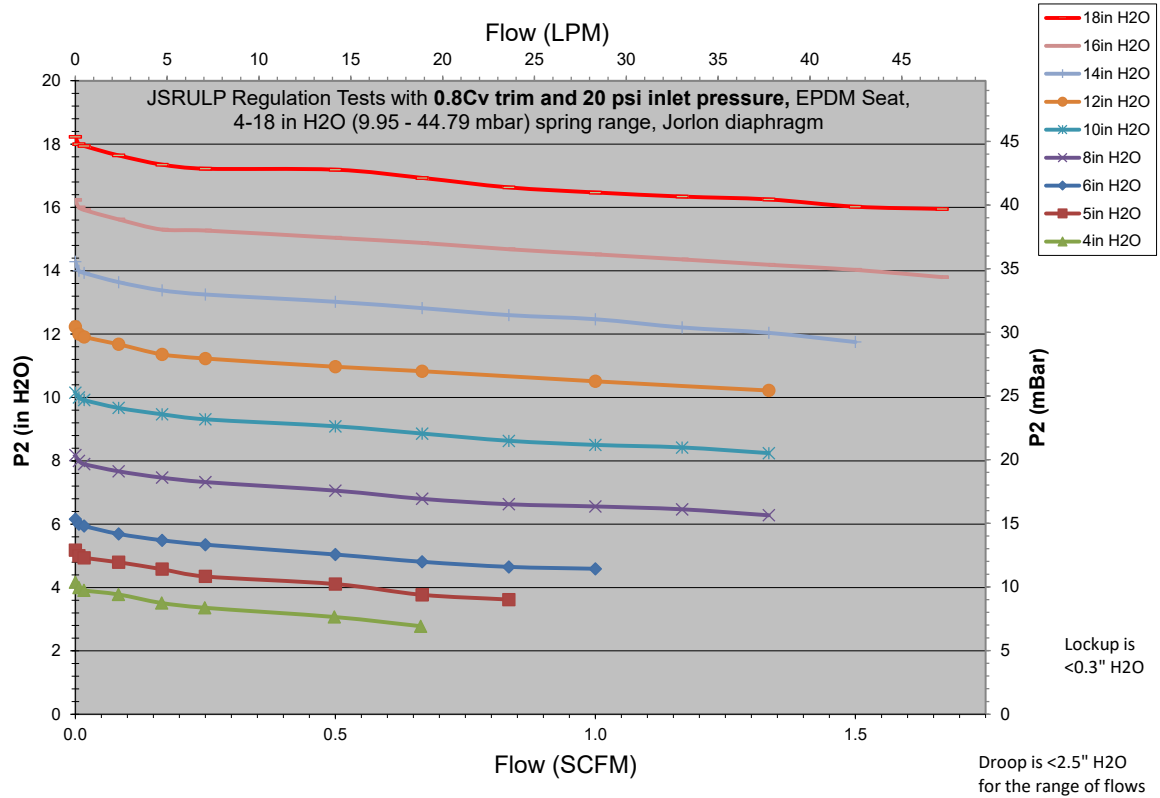

FLOW DATA FOR Cv TRIM SELECTION

The graphs illustrate the change or "droop" in outlet pressures as the flow rate increases, and the lockup (setpoint rise) as flow decreases and approaches zero.

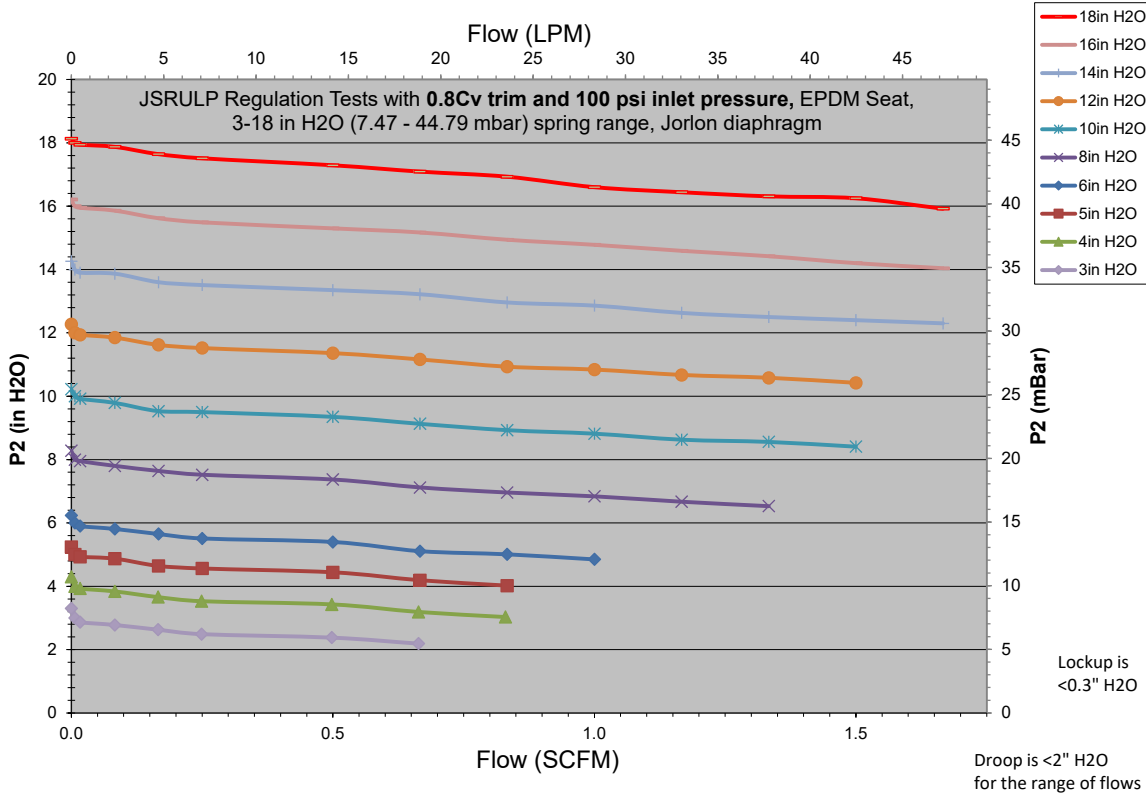
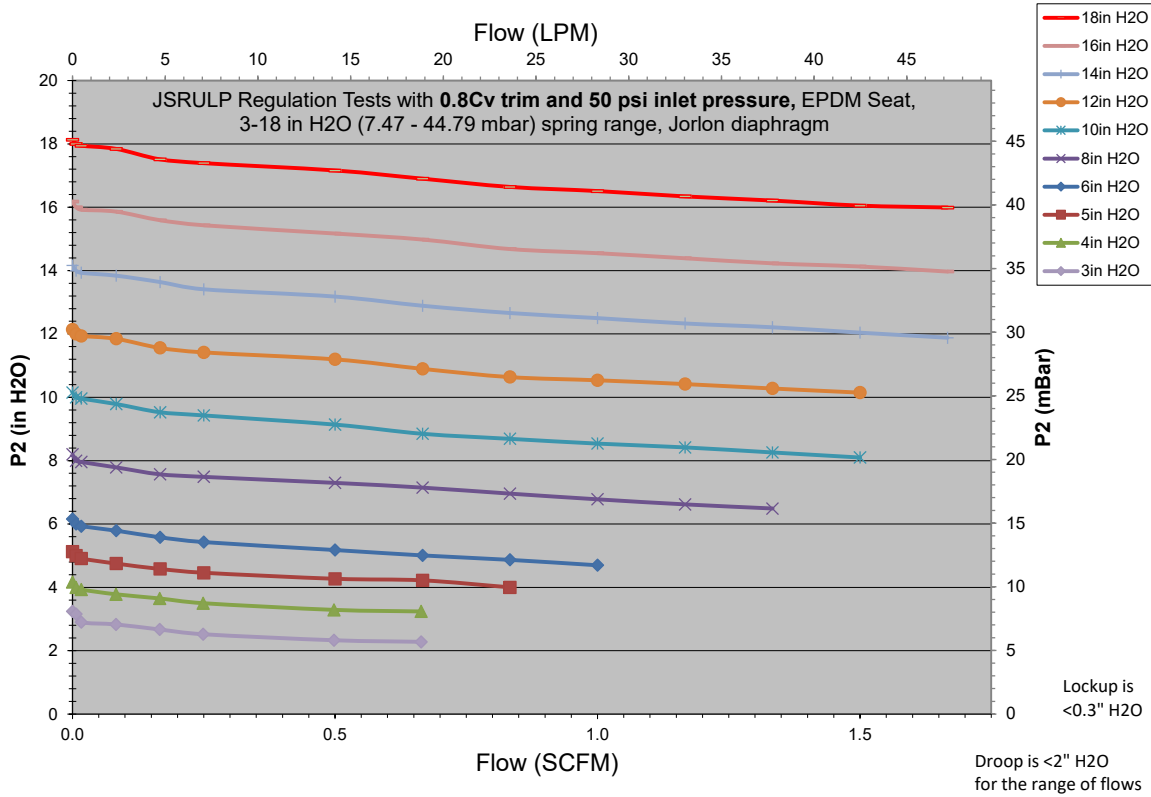

FLOW CONFIGURATIONS/ GAUGE PORTS

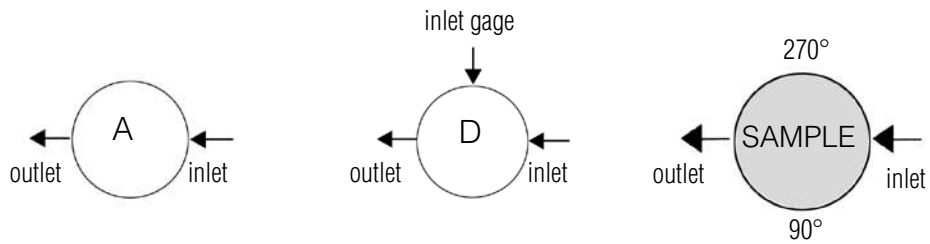

SAMPLE SPECIFICATIONS

Stainless Steel pressure regulator shall be made from ASME SA479 316L, or EN 10272:2000 GR 1.4435 barstock material, which includes body and all wetted stem components. Regulator shall be activated by an un-tied, FDA approved, USP Class VI certified Jorlon diaphragm. Regulator does not require a separate sensing line. Regulator shall be free of exposed threads within wetted process area and valve internal to hold minimal media volume. Regulator shall have trim that can be replaced inline without dome/spring chamber disassembly.

DIMENSIONS, IN. (MM) — 1/2" FOR ASME BPE

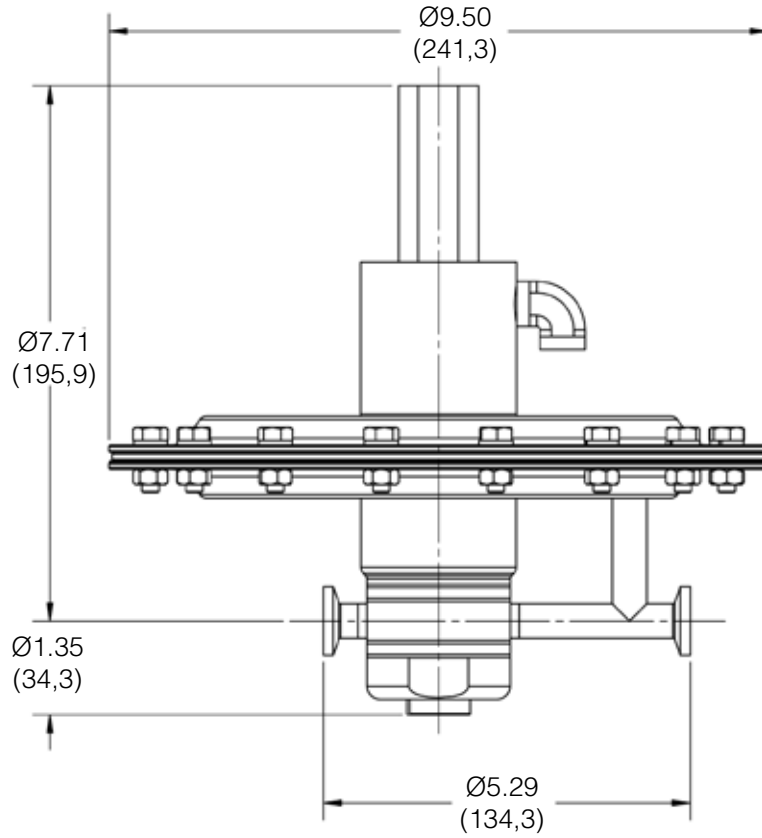

DIMENSIONS, IN. (MM) — 3/4" FOR ASME BPE

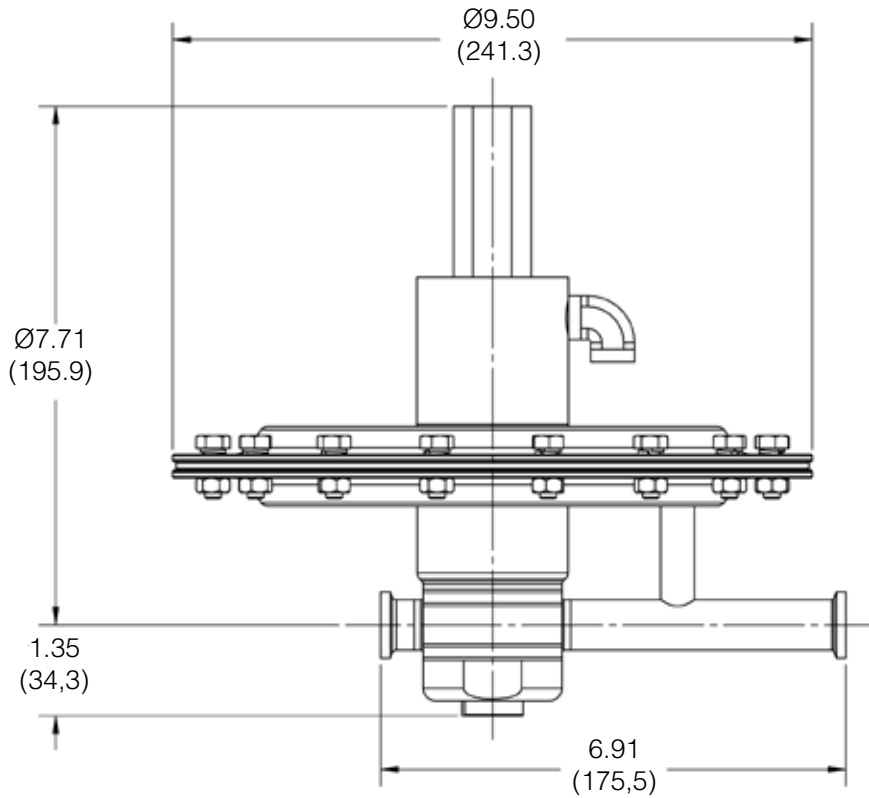

ORDERING SCHEMATIC

Model	Size	Material	1 & 2	3 & 4	5 & 6	7 & 8	9 & 10	11 & 12	13 & 14	15	16	17

Model	
JSRULP	High Purity Gas Pressure Reducing Valve

Size	
050	1/2" (DN15)
075	3/4" (DN 20)

Material	
6L	Stainless Steel 316L

1 & 2	Body Feature	
	End Connection	Port Configuration
C	Tri-Clamp 20 Ra INT	A Port "A"

3 & 4	Trim
1S	0.8 Cv
2S	0.5 Cv
ZZ	Non-Standard

5 & 6	Seat Material
EP	EPDM
ZZ	Non-Standard

7 & 8	Range Spring/Outlet Pressure
A8	3-18" WC (7.47-44.79 mbar)
ZZ	Non-Standard

9 & 10	Diaphragm Material
GL	Jorlon
ZZ	Non-Standard

11 & 12	Actuator
SK	Standard Actuator
ZZ	Non-Standard

13 & 14	Inlet Gauge
0B	0-30 psig/bar (Dual)
0C	0-60 psig/bar (Dual)
0D	0-100 psig/bar (Dual)
0E	0-160 psig/bar (Dual)
0N	None
0Z	Non-Standard

15	Outlet Gauge
0N	None
0Z	Non-Standard

16	SEP Compliance
G	SEP Compliant
0	None
Z	Non-Standard

17	Accessories
S	Clean for Oil Free
X	Clean for Oxygen
A	EN10204 3.1 Cert all Wet
0	None
Z	Non-Standard

REPAIR KIT ORDERING SCHEMATIC

Model	Size	Material	Kit	1&2	3&4	5&6
				/		

Model	
JSRULP	High Purity Gas Pressure Reducing Valve

1 & 2	Trim/Seat Material
1E	Cv 0.8/EPDM
2E	Cv 0.5/EPDM
ZZ	Non-Standard

Size	
050	1/2"
075	3/4"

3 & 4	Diaphragm Assembly
SJ	Standard Jorlon
ZZ	Non-Standard

Material	
6L	Stainless Steel 316L

5 & 6	Accessories
0S	Clean for Oil Free
0X	Clean for Oxygen
01	Non-Standard

Kit	
KT	Repair Kit



Steriflow, a division of Jordan Valve
 3170 Wasson Road • Cincinnati, OH 45209
 513.533.5600 • 800.543.7311 • 513.871.0105 (f)
 steriflow@richardsind.com • www.steriflowvalve.com