

Mark 95A Series

Sanitary Air Loaded Pressure Regulators

The Mark 95A is an air loaded sanitary back pressure reducing valve designed to allow the user to change set-points remotely via a cabinet or panel mounted air regulator, or through a distributed control system or PLC, using an I-P transducer.

The Mark 95A is an ideal choice for automating the pressure set points for all of your back pressure control operations whether they are process set points or set points to fully open the valve for Rinse, CIP or SIP.

An accessory I/P wired to a stand alone controller, PLC or DCS and an air supply will allow fully automated operation based on menu commands. Users may also opt to control the set point remotely via pneumatic tubing from a remote (panel or cabinet mounted) self-relieving instrument air regulator. Note: If using regulator we recommend the JSRLF-025 with Teflon Seat, or JSRLF-025 (EPDM seat) specified with a .2 Cv and self relieving option.

Unique among its competitive peers, the MK95A is normally open when the air supply is removed, allowing process or sanitization fluids to drain.

FEATURES

- Normally open when air supply is removed
- Compact design significantly reduces the installation space and weight if mounting the valve on a process skid.
- Permits full automation of Process, Rinse, CIP and SIP setpoints.
- Valve body and trim is the same as the time-tested MK95 design
- Optimized diaphragm material, surface area and support system for unsurpassed performance and life.
- Accessory I/P or Air regulator available for automated, and/or remote set point control

DOCUMENTATION

The following documentation is shipped with each order:

- Steriflow Unicert, a QC signed Certificate or Compliance for
 - Material, listing heat numbers with attached
 - Surface
 - FDA/USP Class VI - for all thermoplastic and elastomer components



- Traceability
 - Each individual product serial number is traceable to the Unicert serial number, heat numbers and attached MTR's.

Other documents must be requested at time of RFQ, or order:

- ADI/TSE Free, Certified Test reports, Certificate of origin

APPLICATIONS

A wide variety of applications exist for the MK95A in the biopharmaceutical, biotech, healthcare, food & beverage and other industries including:

- Pump pressure control
- Process overpressure control
- TFF Retentate pressure control
- WFI or USP PW end of loop pressure control
- Buffer dilution pressure control
- CIP system pressure control
- Pressure bypass control

SPECIFICATIONS

Sizes: 1/2" (DN15), 3/4" (DN20), 1" (DN25), 1-1/2" (DN40), 2" (DN50)

Wetted Material: ASME SA479 316L (UNS 31603) is standard. EN 10272:2000 GR 1.4435, AL-6XN®, Hastelloy®C-22 and others are optional.

End Connections: ASME Tri-Clamp, butt weld, others consult factory

Cv:

Valve Size	Available Cv (Kv)	Cv for Relief Valve Sizing
1/2", DN15 3/4" DN20	0.5, 1.5 (0,43; 1,3)	0.6 (0,52)
1" DN25	1.5, 3.0, 4.5, 5.5** (1,3; 2,6; 3,9; 4,7)	1.8, 3, 5.4, 6.6, 7.3 (1,6;2,7; 4,7; 5,7; 6,4)
1-1/2" DN40	4.5 or 10.0 (3,9 or 8,6)	5.4 (4,68) 12 (10,32)
2" DN50	10.0 or 19.0 (8,6 or 16,3)	12 (10,32) 22.8 (19,56)

Seat Material: Teflon® (FDA, USP CL 6 approved), PEEK (FDA, USP CL 6 approved) optional

Shutoff: ANSI Class VI

Actuator Housing: Air-loaded, clear coat anodized aluminum housing (standard) or electropolished 316 Stainless Steel (optional)

O-Ring Material: FDA, USP CL 6 approved Teflon-Encapsulated Viton

Diaphragm Material: Jorlon (FDA, USP CL 6 approved)

Min Pressure Drop: 3psi

Maximum Operating Pressure @ Maximum Temperature: 200 psi @ 300°F (13,8 bar @ 149°C)

Max Set Point: 1/2" - 1": 3-105 / 1-1/2": 3-85 / 2": 5-60; 3": Consult factory

Maximum Air Supply Pressure: 110 psi

Weight:

- 1/2"-1" – 12.0 lbs (5,4 kgs) – Aluminum
- 1"/2"-1" – 12.5 lbs (5,7 kgs) – Stainless Steel
- 1-1/2" – 31.0 lbs (14,1 kgs) – Aluminum
- 1-1/2" – 34 lbs (15,4 kgs) – Stainless Steel
- 2" – 69 lbs (31,3 kgs) – Aluminum
- 2" – 72 lbs (32,7 kgs) – Stainless Steel
- 3" Consult with Factory

DIMENSIONS

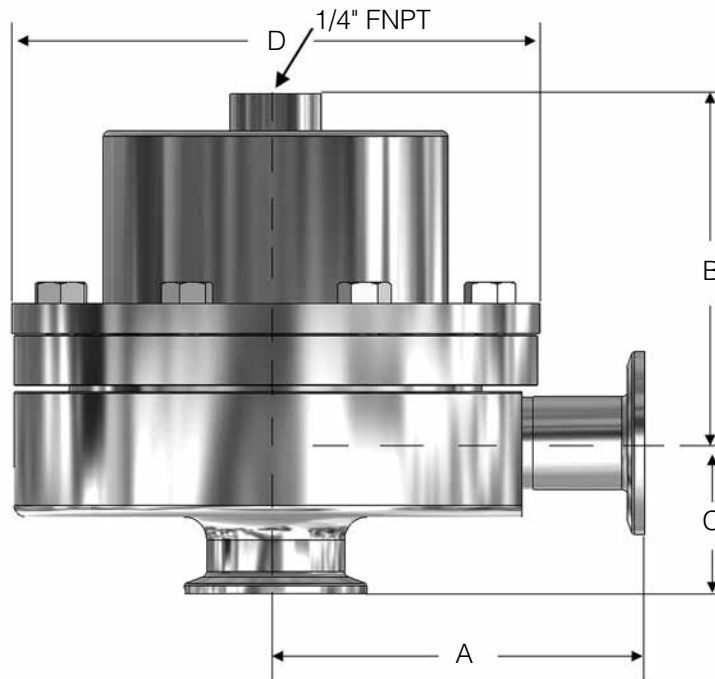

Valve Size	Dimensions (inches)			
	A	B	C	D
1/2"	3.29	3.80	1.375	5.75
3/4"	3.29	3.80	1.375	5.75
1"	4.00	3.80	1.64	5.75
1-1/2"	4.21	6.40	2.53	7.22
2"	5.34	6.75	2.96	9.50

Consult Factory for 3" requests

Valve Size	Dimensions (mm)			
	A	B	C	D
DN15	83,6	96,5	34,9	146,1
DN20	83,6	96,5	34,9	146,1
DN25	101,6	96,5	41,7	146,1
DN40	106,9	162,6	64,3	183,4
DN50	135,6	171,5	75,2	241,3

Based on US tri-clamp ends. Consult factory for DIN and ISO tri-clamp end dimensions

AVAILABLE FINISHES

Body

- *Standard:* 20 Ra μin (0,5 Ra μm) (ASME BPE SF5) mechanical finish and electropolish on inside wetted surfaces; machine finish and electropolish on exterior.
- *Optional:* 20 Ra μin (0,5 Ra μm) SF5 mechanical finish and electropolish on external surfaces; 8 Ra μin (0,2 Ra μm) finish on internal or external finishes and electropolish (Better than SF4)

Bonnett Dome

- *Standard:* 20 Ra μin (0,5 Ra μm) machine finished and electropolished 316SST. If aluminum, not electropolished
- *Optional:* 20 Ra μin (0,5 Ra μm) mechanical finish and electropolish on external surfaces (SF5). 8 Ra μin (0,2 Ra μm) finish on external surfaces on all sizes and electropolish. (Better than SF4). If aluminum, not electropolished

MARK 95A SERIES CUT-A-WAY

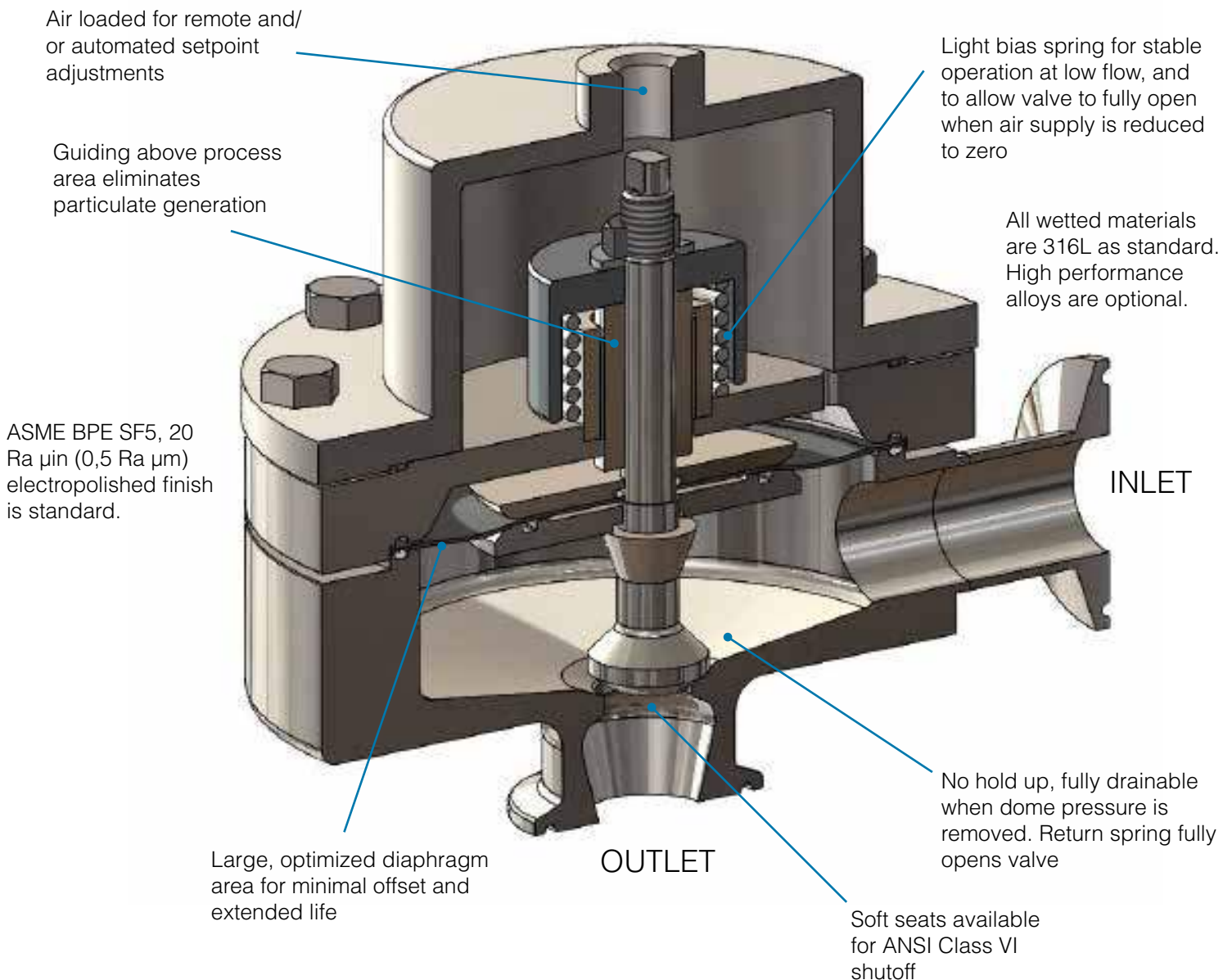

MAXIMUM INLET PRESSURE VS SETPOINT

Notes:

1. Valve actuator loading pressure (supply pressure) must be at least 2 psi above the desired outlet pressure setpoint. This is needed to overcome the opening spring bias.

Installation Notes:

- As with all regulators and control valves, optimal flow performance can only be achieved with a non-turbulent flow profile. The Mark 95A should be installed with 3 feet (0,9m) of straight pipe on either side of the valve.
- A pressure gauge, or transmitter reading upstream of the Mark 95A should be used to make the final setpoint adjustment.

ORDER SCHEMATIC

Model	Size	Material	1	2	3	4	5	6	7	8	9	10	11	12
95A	050	6L	/											

Model	
95A	Standard

Size	
050	1/2" (DN15)
075	3/4" (DN20)
100	1" (DN25)
150	1-1/2" (DN40)
200	2" (DN50)
300	3" (DN80): Contact Factory for Availability

Material	
6L	316L Stainless Steel

1 & 2		Body		
		Finish	Cv	
A	20ra Interior/40rms Exterior (standard)	H	4.5	
B	20ra Interior/20ra Exterior	M	10	
C	8ra Interior/63rms Exterior	N	19	
D	20ra Interior/8ra Exterior	A	0.5-1.5	
E	8ra Interior/8ra Exterior	G	3.0	
F	8ra Interior/20ra Exterior	K	5.5	
ZZ				

3 & 4		Trim		
		Finish	Cv & Seat	
A	20ra (standard)	8	Cv 0.5 TFE	
B	8ra	9	Cv 1.5 TFE	
		F	Cv 3.0 TFE	
		J	Cv 4.5 TFE	
		M	Cv 5.5 TFE	
		Q	CV 10 TFE	
		T	CV 19 TFE	

5 & 6		O-Ring/Diaphragm	
TY	TFE Encaps. Viton/Jorlon Diaph. > 3Cv		
TG	TFE Encaps. Viton/Jorlon Diaph. 0.5-3Cv		
ZZ	Non-Standard		

7 & 8		Air Loading I/P Transducer Option	
		Type of Loader Max Load (psi)	
00	None		
AP	I/P Transducer, 4/20 MA / 60 psi output		
AH	I/P Transducer, 4/20 MA / 120 psi output		
AN	I/P Transducer 4-20M/2-60P (NEMA 4XS)		

NOTE: As an alternate air loading device, you can use a JSRLF or JSRLF (Teflon or EPDM seat) with 1/4" FNPT connection, .2 Cv, and self relieving feature. These air regulators must be ordered separately.

9 & 10		Diaphragm	
JL	Jorlon		

11 & 12		Actuator	
AA	Anodized Aluminum		
BA	63rms Electropolished SST		
CA	20ra Electropolished SST		
DA	8ra Electropolished SST		
ZZ	Non-Standard		



Steriflow, a division of Jordan Valve
 3170 Wasson Road • Cincinnati, OH 45209
 513.533.5600 • 800.543.7311 • 513.871.0105 (f)
 steriflow@richardsind.com • www.steriflowvalve.com

Steriflow Valve reserves the right to make revisions to its product, specifications, literature and related information without notice. Please visit our website at www.steriflowvalve.com for the latest information on our products.